

PHYSICS

Time Allowed – 1.5 hours

This examination paper consists of two sections, A and B. Section B is composed of seven independent questions. Try to attempt all the questions from Section A and at least six questions from Section B. (If you answer all the seven questions in Section B, the best six will contribute to your overall mark.)

Use the notebook(s) provided to work out your solutions.

Please clearly indicate each question number ahead of your working out and answers, and highlight your final numerical answers (including units) by, for example, underlining or framing them.

Marks will be awarded for correct approaches, thoughts, ideas, or methods, even if the final answer is incorrect or missing. No negative marks will be awarded for inaccurate or faulty arguments or incorrect answers.

The following lists of fundamental constants and formulae should be more than sufficient to answer all questions. However, standard booklets of fundamental constants and/or formulae, provided by your school, may be used in addition.

Any calculators are allowed to be used.

Fundamental Constants

Electron charge	$e = 1.60 \times 10^{-19} \text{ C}$
Electron mass	$m_e = 9.11 \times 10^{-31} \text{ kg}$
Gravitational constant	$G = 6.67 \times 10^{-11} \text{ m}^3 \text{ kg}^{-1} \text{ s}^{-2}$
Plank's constant	$h = 6.63 \times 10^{-34} \text{ m}^2 \text{ kg s}^{-1}$
Speed of light	$c = 3.00 \times 10^8 \text{ m s}^{-1}$
Gas constant	$R = 8.31 \text{ J K}^{-1} \text{ mol}^{-1}$

Further Useful Constants

Gravitational acceleration	$g = 9.8 \text{ m s}^{-2}$
Mass of an alpha particle	$m_\alpha = 6.64 \times 10^{-27} \text{ kg}$
Boltzmann constant	$k_B = 1.38 \times 10^{-23} \text{ J K}^{-1}$
Astronomical unit	$1 \text{ AU} = 1.5 \times 10^{11} \text{ m}$
Ångström	$1 \text{ Å} = 10^{-10} \text{ m}$
Electronvolt	$1 \text{ eV} = 1.6 \times 10^{-19} \text{ J}$
Avogadro number	$N_A = 6.22 \times 10^{23} \text{ mol}^{-1}$
Temperature conversion	$T_K - T_{\text{C}} = 273.15$

Useful Formulas

$$PV = Nk_B T$$

$$PV = nRT$$

$$n = \frac{N}{N_A}$$

$$M = \frac{m}{n}$$

$$\Delta U = cm\Delta T$$

$$v \equiv \frac{dx}{dt}$$

$$a \equiv \frac{dv}{dt}$$

$$\omega = \frac{2\pi}{T}$$

$$s = s_0 + ut + \frac{1}{2}at^2$$

$$v = u + at$$

$$a_n = \frac{v^2}{r}$$

$$y = u_y t - \frac{1}{2}gt^2$$

$$x = u_x t$$

$$E_{\text{kin}} = \frac{1}{2}mv^2 = \frac{p^2}{2m}$$

$$E_{\text{pot}} = -\frac{GMm}{r}$$

$$E_{\text{pot}} = mgh$$

$$F_e = k\frac{qQ}{r^2}$$

$$F_g = \frac{GMm}{r^2}$$

$$E = hf$$

$$c = \lambda f$$

$$\lambda_0 = 2L$$

$$\lambda_B = \frac{h}{p}$$

$$N = N_0 2^{-\frac{t}{\tau}}$$

$$F = PA$$

$$E = mc^2$$

$$g = \frac{GM}{r^2}$$

$$\rho = \frac{m}{V}$$

$$A = \pi r^2$$

$$V = IR$$

$$q = CV$$

$$E_J = Vq$$

$$q = It$$

$$q = Ne$$

$$P = IV = I^2 R = \frac{V^2}{R}$$

$$\sum I_i = 0$$

$$\sum V_i = 0$$

$$c = \frac{c_{\text{vacuum}}}{n}$$

$$\frac{1}{f} = \frac{1}{o} + \frac{1}{i}$$

$$M = \frac{i}{o}$$

$$n_1 \sin \alpha_1 = n_2 \sin \alpha_2$$

SECTION A

Experimental Data Analysis to Determine the Stefan-Boltzmann Constant

An object that can absorb and radiate electromagnetic waves at any wavelength or frequency is called a black body. Stefan-Boltzmann law states that the energy, E , radiated by a black body per unit time, t , is proportional to the surface area, A , of the body and to the fourth power of the surface temperature, T , of the black body, where the temperature is given in kelvins:

$$I \equiv \frac{E}{t} = \sigma AT^4$$

The Greek letter, σ (sigma) is for the Stefan-Boltzmann constant.

In an experiment, an object with surface area of $A = 1.5 \times 10^{-3} \text{ m}^2$ was heated to four different temperatures, and its radiation power, I (radiated energy per unit time), was measured each time. The results are the following:

T ($^{\circ}\text{C}$)	450	490	550	620
I (W)	23.6	26.3	41.1	53.8

a)

Convert the temperatures from Celsius degrees to kelvins.

[4]

b)

Calculate the fourth power of each of the four temperature values obtained in a).

[2]

c)

Plot the radiation power, I , as a function of T^4 .

[5]

d)

Draw a straight line through the data points the gradient of which could give the ratio between I and T^4 .

[2]

e)

Derive a value for the Stefan-Boltzmann constant.

[5]

f)

Suggest two or three reasons why the derived value is not exactly equal to the literature value of the Stefan-Boltzmann constant.

[2]

SECTION B

1

To what frequency do you have to tune your music player to find your radio station which broadcasts at a wavelength of $\lambda = 200 \text{ m}$?

(Radio waves propagate at the speed of light, $c = 3 \times 10^8 \text{ m s}^{-1}$)

[5]

2

Water in Eikesdal Valley (Norway) dives into Eikesdalsvatn Lake from a height of 630 m. Assuming that 70 % of the potential energy of the water changes into the internal energy of the water, how much is the temperature increase of the water during its fall? (Specific heat capacity of water is: $c = 4.2 \text{ kJ kg}^{-1}\text{°C}^{-1}$)

[5]

3

What happens to the volume of an ideal gas in a piston if the gas pressure in the piston rises by 50 % while the gas is heated from $T_1 = 40 \text{ °C}$ to $T_2 = 60 \text{ °C}$?

[5]

4

The carbon-14 activity in a wooden archeological object was measured to be 78.5 % of the estimated original natural abundance. How old is the artifact?

(It can be assumed that the same amount of ^{14}C was initially present in the object as now in the fresh sample. The half life of ^{14}C is $T = 5730 \text{ yr.}$)

[5]

5

The ammeter (A) in a circuit with a voltage, V , from a battery and three resistors, R_1 , R_2 , and R_3 , (Figure 1) measures 1.5 mA. After swapping resistors R_1 and R_2 (Figure 2), what will the measured current be?

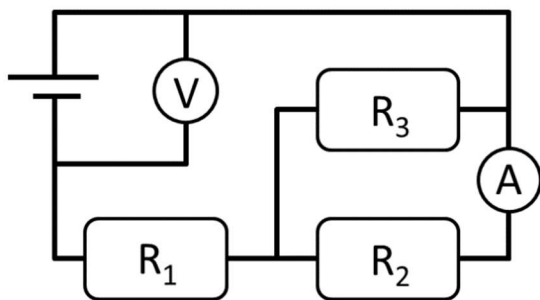

Figure 1

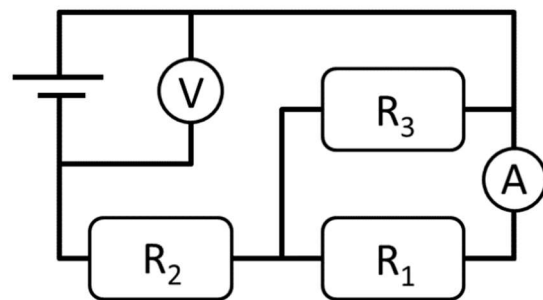

Figure 2

[5]

6

A satellite (sat) at Point P along the line connecting the Sun (S) and the Earth (E) experiences zero net gravitational force exerted by the Sun and the Earth:

$$F = F_S - F_E = \frac{GM_{\text{sat}}M_S}{D_S^2} - \frac{GM_{\text{sat}}M_E}{D_E^2} = 0$$

Here, G is the gravitational constant, and $M_{\text{sat}} = 3420 \text{ kg}$, $M_S = 3 \times 10^{30} \text{ kg}$, and $M_E = 6 \times 10^{24} \text{ kg}$, are the masses of the satellite, Sun, and Earth, respectively. D_S and D_E are distances of the satellite from the centres of the Sun and Earth, respectively. (Note that one astronomical unit is: $D = D_S + D_E = 1 \text{ AU} = 1.5 \times 10^{11} \text{ m}$)

Find the distance, D_E , of point P from the centre of the Earth and calculate how many Earth-size objects could be fit along the line between the Earth and point P.

The Earth's diameter is: $d_E \approx 1.3 \times 10^7 \text{ m}$

[5]

7

A thin lens creates a real image of an object at a distance of $d = 40 \text{ cm}$ away from the object. The size of the image is $M = 4$ times the size of the object. What is the focal length of the lens: $f = ?$

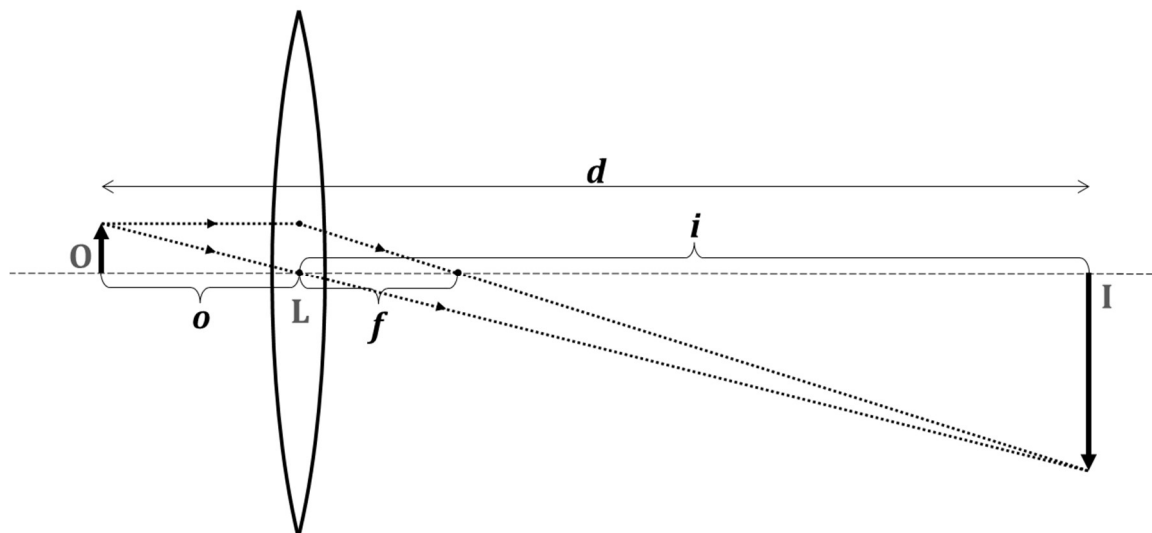

The thin lens equation is:

$$\frac{1}{f} = \frac{1}{o} + \frac{1}{i}$$

where o and i are the distances of the object and the image from the lens, respectively. The ratio between the sizes of the image and object (magnification) equals the magnification of the lens:

$$M = \frac{i}{o}$$

[5]

– END OF QUESTIONS –